

VariQtire tire pressure control system for agricultural tractors

Efficient soil protection with the VariQtire tire pressure control system

In view of increasing environmental pollution, soil protection is becoming increasingly important. Optimal tire pressure protects the soil, reduces compaction, improves driving comfort, lowers fuel consumption, and extends the service life of tires.

The VariQtire tire pressure control system precisely adjusts pressure while driving, thereby optimizing efficiency. The multi-line system combines the advantages of two-line and single-line systems and offers a pressureless standby mode, compact design, easy installation and high safety.

Robust technology for maximum precision and safety

The innovative design of the VariQtire tire pressure control system allows for integrated, internal mounting of the rotary unions without axle bores, secured between the axle and rim using retaining stars. Battery-powered tire pressure sensors with safety valves (DBV) in the rims send the tire pressures wirelessly to the central box and display them in real time on the terminal. Pressure changes are also recorded and displayed in real time.

The intelligent wheel changeover valves in the rims have two positions controlled by pressure pulses for filling or deflating. At 2.5 bar, the first position opens for deflation; above 4 bar, filling takes place. When there is no pressure, the valve remains securely closed.

The software allows individual pressure settings for each wheel. This means that tire pressure can be adjusted as needed and in a targeted manner – even with different load conditions between the wheels.

Maximum safety

The lines remain unpressurized when not in use, while spring-loaded wheel changeover valves are always securely closed. High-precision pressure sensors and safety valves (DBV) ensure permanent pressure monitoring and the highest safety standards. In the event of a system failure, all valves remain sealed so that the vehicle is ready to drive at any time.

Robust, low-wear and easy to maintain

The virtually wear-free, ball-bearing rotary union ensures reliable air transfer. Internal seals are only pressed against the rotor when pressure is applied and remain untouched in standby mode, which significantly minimizes wear. External labyrinth seals, in combination with lubricating grease, reliably protect the system from dirt and dust. When it comes to maintenance, the system impresses with its compact design and easily accessible components, allowing repairs to be carried out quickly and easily.

Complete solution for flexible retrofitting

The **IWN complete solution** can be conveniently controlled via an ISOBUS interface. Alternatively, a stand-alone version with an intuitive control terminal is also available. Central box, screw-in radio sensors with DBV, wheel changeover valves, and rotary unions for each axle. The system is compatible with all common vehicle sizes and can be fully installed and ready for use within one to one and a half working days.



Smart control technology with high safety standards

1



Fully integrated,
retrofitable complete
system

- Integrated, internal system – no distance control required (§32 StVZO)
- Can be retrofitted and flexibly integrated
- ISOBUS & Stand-Alone
- Complete solution with all components
- Individual wheel control

2



Easy installation,
compact & low
maintenance

- Compact design for quick installation (1–1.5 working days)
- Easily accessible components for simple maintenance
- Low-wear, durable components
- Intelligent sealing systems
- Ideal for efficient, stress-free, and user-friendly retrofitting

3



High security

- Pressureless lines in standby mode
- Securely closed, spring-loaded wheel valves
- Labyrinth seals for protection against dirt and dust
- Pressure sensors and DBV for permanent, precise pressure control and overload protection
- Ready to drive and leak-proof even in the event of system failure



VariQtire tire pressure monitoring system

Technical data

Designation	VariQtire tire pressure control system
Function	Precise wheel-specific control of tire pressure from 0,4 bar to 3 bar
Accuracy	±0,1 bar
Supply pressure	6 bar to 8,5 bar
Max. permissible pressure	10 bar
Compressed air source	Onboard compressor or auxiliary compressor
Volume flow	Min. 200 l/min up to 2800 l/min
Power supply	9 V to 16 V (24 V to 36 V, briefly 48 V) can be used for vehicles with 12 V electrical system
Current consumption	6 A
Temperature range	-10°C to +60°C
Display	Stand-Alone Terminal / ISOBUS
Mechanical connection rotary unions	Via retaining star on axle flange (Plug and Play)
Rim bore	2x G1/2" per rim

Materials

Central box	Aluminium (anodized), Stainless steel, Brass, NBR, HNBR
Rotary union	HartCoat-coated aluminium, HNBR, PTFE, Brass, PA 6.6
Wheel change valve	Stainless steel, Brass, PUR, NBR, PE
Wireless sensor with safety valve	Stainless steel, Brass, POM, NBR
Connection adapter	Aluminium, anodized NBR Steel, galvanized
Torque support	Steel, galvanized Stainless steel Igubal

Central box

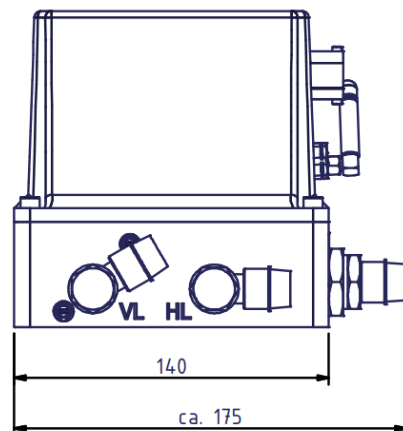
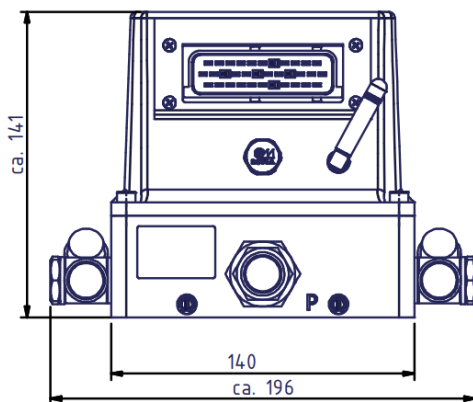
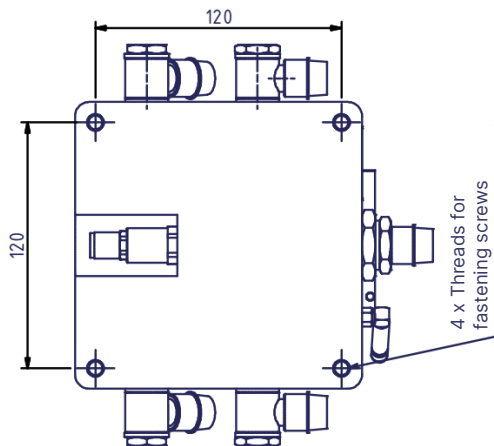

Technical data

Designation	Central box
Dimensions	196 x 175 x 141 mm
Weight	3,48 kg
Supply pressure	6 to 8,5 bar
Max. permissible pressure	10 bar
Temperature range	-30°C to +80°C (Lagerung) -10°C to +60°C (Funtion)
Material	Aluminium (anodized), Stainless steel, Brass, NBR, HNBR
Electronic interface/ Signal transmission	HS-CAN according to ISO 11898-2
Antenna	433 MHz, SMA
Power supply	9 V to 16 V (24 V to 36 V, briefly 52 V) Suitable for vehicles with 12 V electrical system IP64
Protection class	IP64
Control medium	Compressed air according to ISO 8573-1:2010 [7:4:4] Control medium filtered 40µm, free of aggressive components

Wheel changeover valve



Technical data

Designation	Wheel changeover valve
Dimension	180 x 55 x 47 mm
Weight	0,32 kg
Permissible pressure	12 bar
Supply line for hose	Ø12/ Ø10 or Ø12/ Ø9
Temperature range	-40°C to +80°C (storage) -30°C to +60°C (operation)
Tightening torque for rim	50 Nm (SW30)
Connection thread in rim	G 1/2"
Material	Stainless steel, Brass, PUR, NBR, PE
Control medium	Compressed air according to ISO 8573-1:2010 [7:4:4] Control medium filtered 40µm, free of aggressive components

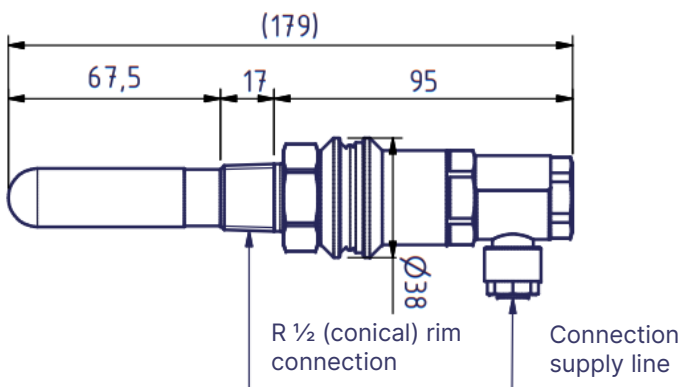

Wireless sensor R1/2 with safety valve

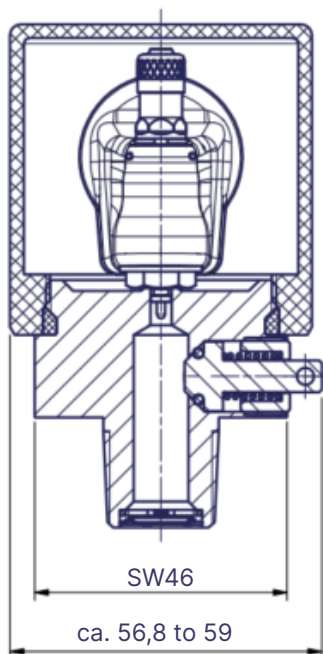
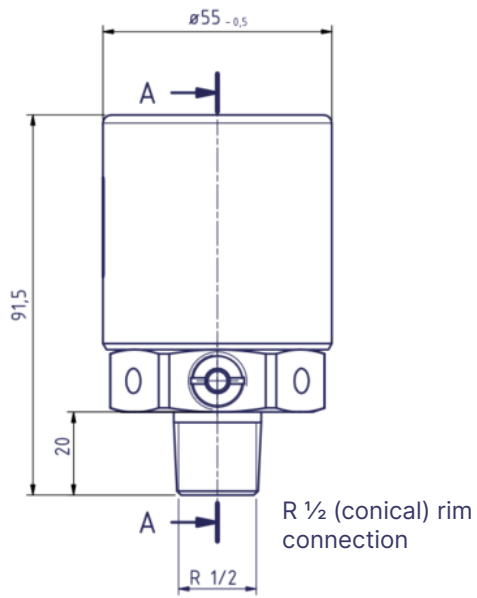

Technical Data

Designation	Wireless sensor R1/2 with safety valve
Dimension	$\varnothing 55 \times 92 \text{ mm}$
Weight	0,39 kg
Tightening torque Rim	50 Nm (SW46)
Connection thread in rim	G 1/2"
Pressure Measuring range	0 – 12 bar
Measuring accuracy	$\pm 0,1 \text{ bar}$
Opening pressure	3 bar
Flow rate	720 l/min
Temperature range	-25°C to +80°C
Material:	Stainless steel, Brass, POM, NBR
Control medium	Compressed air according to ISO 8573-1:2010 [7:4:4] Control medium filtered 40 μm , free of aggressive components

